

# Line Interface

**FT 634**

**FT 634 C**

**FT 634 CL**

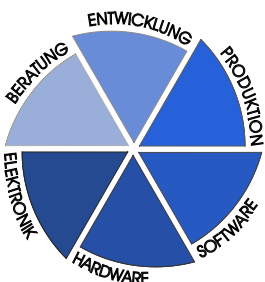

**FunkTronic**  
Kompetent für Elektroniksysteme

English Version 1.0

# Line Interface FT634 / FT634C / FT634CL

There are two housing versions of the Line Interface FT634. One in a black box and one in a 19 inch box. The FT634 is used for higher distances between control head and radio over an own or rented 2- or 4 wire.

The FT634 is approved by TBR 15 and TBR 17. All audio signals are coupled via transformers.

## Standard version FT634

To connect a control head or a radio there is PTT in/output, the audio in/output and supply contact. On the other side you connect the two- or four wire.

## Micro controller version FT634C

Additionally there are four digital outputs. For example it can be used for channel switching.

The 19 inch version has 6 digital outputs and 6 digital inputs.

## Micro controller version FT634CL

Additionally the line is watched of disconnect failure.

## Squelch/PTT input (FT 634 C/CL)

The logic input of squelch/PTT is set in register 01 on 3rd digit.

Registers 01

- 3. digit SQL/PTT input active, if
  - 0 = LOW (<0,6 V) (factory default)
  - 1 = HIGH (> 3V)

Furthermore, one can configure Jumper JP10, whether the output of the radio/controlhead connected at the SQL/PTT input

- also the logical HIGH actively switches or
- only the logical LOW level actively to GND can switch  
(for example with an Open-Collector to GND)

In the more final case an internal Pull-Up-Resistor is connected. See also section configuration of the Jumper.

## Jumper JP10

HIGH of the SQL/PTT input switched through

- 1 = active voltage (> 3 V)
- 2 = keep open (Open-Collector)

## Transmitter control/carrier display (FT634)

The Transmitter control/carrier display (PTT/SQL-output) switches on, as soon as from the AC-Line the pilot-tone (3300 Hz) is received.

That FT 634 switches the TX/SQL-output through a potential-free relay as a result.

## Transmitter control/carrier display (FT634 C/CL)

The Transmitter control/carrier display (PTT/SQL-output) switches on, as soon as either from the AC-Line the pilot-tone (3300 Hz) or an audio signal (Audio-Squelch) is received.

In 2 wire mode/simplex the Squelch/PTT input must not be activated, since his function priority has sets the Audio-Squelch out of order and puts down the pilot-tone.

Register 01

- 1. digit PTT/SQL-output switches through:
  - 0 = pilot tone decoding (2 wire/simplex)  
{not with active Squelch-/PTT input!}
  - 1 = pilot tone decoding (4 wire/duplex)  
{always!}
  - 2 = audio squelch (2 wire/simplex)  
{not with active Squelch-/PTT input!}
  - 3 = audio-squelch (4 wire/duplex)  
{always!}

The FT634C/CL switches the PTT/SQL output through a potential-free relay as a result.

The audio squelch mode is only for the application as controlhead interface, to recommend, since a TX switching on is normally too uncertain over audio squelch.

## Samples how to connect and to program

The programming of the FT634 has to be according to the application.

The following considerations should be done:

- FT634 connected to the control head or to the radio
- Channel remote control necessary?
- Line watching necessary?
- AC Line two or four wire, simplex or duplex?
- Opposite a FT634 or a controlhead (for example major 3,4,5)?

In the following examples the most important EEPROM registers 01, 05, 08 and 12 are listed.

**Hint:** x marked digits are without importance or depends on customer application.

### Sample 1: Controlhead Major 5, opposite a one channel radio

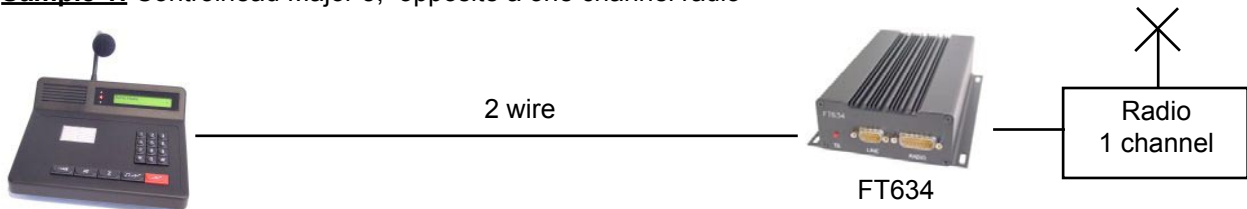

Major 5  
EE-Reg 33 = 00046

### Sample 2: Controlhead Major 5, opposite a multichannel radio

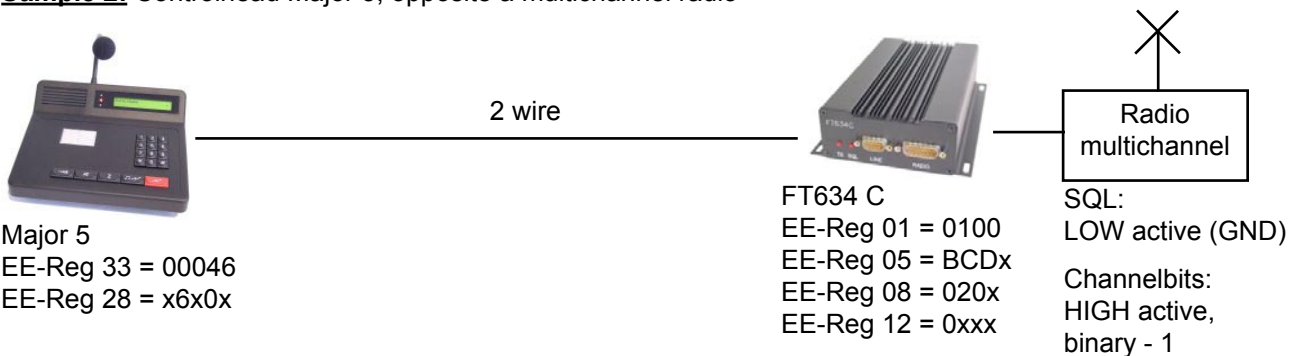

Major 5  
EE-Reg 33 = 00046  
EE-Reg 28 = x6x0x

FT634 C  
EE-Reg 01 = 0100  
EE-Reg 05 = BCDx  
EE-Reg 08 = 020x  
EE-Reg 12 = 0xxx

SQL:  
LOW active (GND)  
Channelbits:  
HIGH active,  
binary - 1

### Sample 3: Controlhead Major 6, opposite a one channel radio

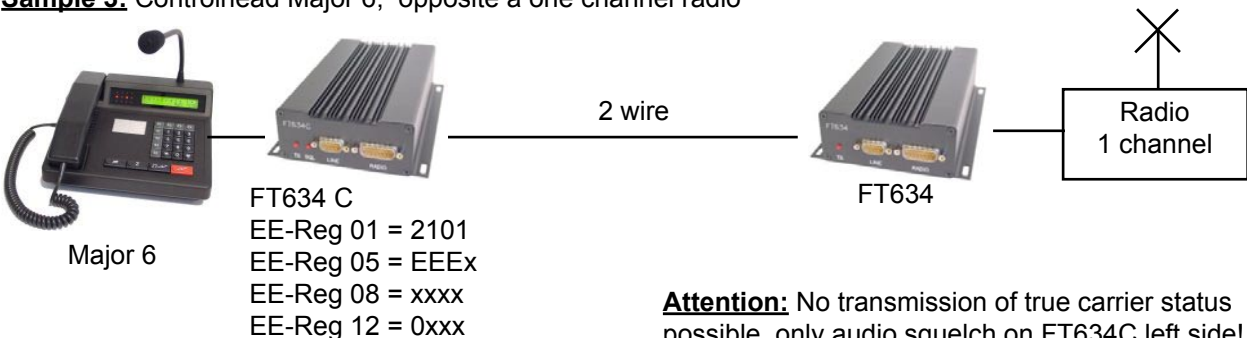

Major 6  
FT634 C  
EE-Reg 01 = 2101  
EE-Reg 05 = EEEEx  
EE-Reg 08 = xxxx  
EE-Reg 12 = 0xxx

**Attention:** No transmission of true carrier status possible, only audio squelch on FT634C left side!

**Sample 4:** Controlhead Major 6, opposite a 1 channel radio, true transmission of carrier status

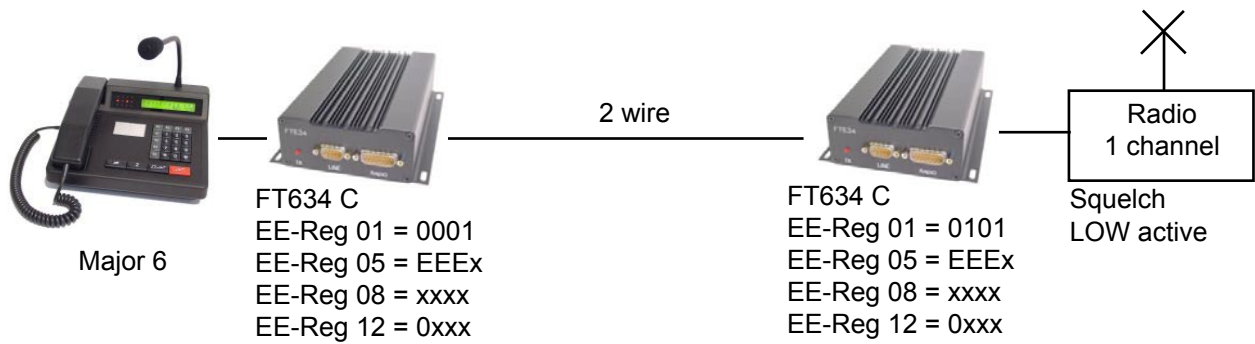

**Sample 5:** Controlhead Major BOS 2, opposite a full duplex radio

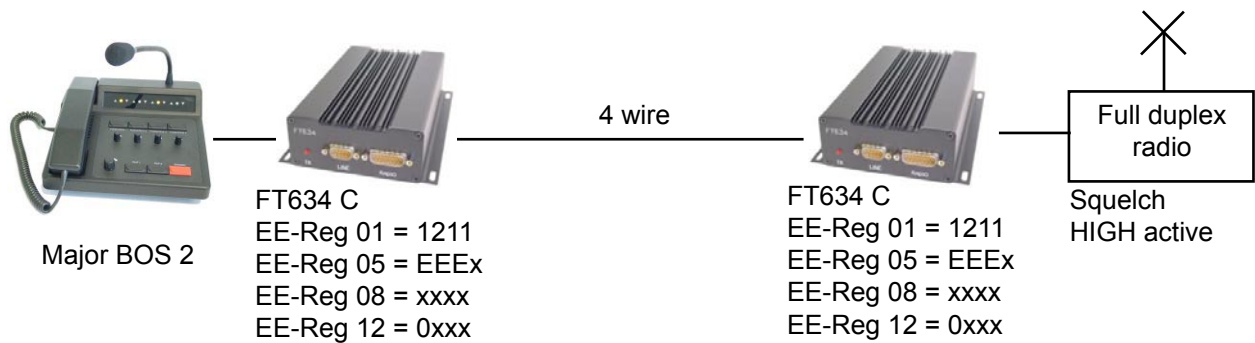

**Sample 6:** Controlhead Major 6 on multichannel radio

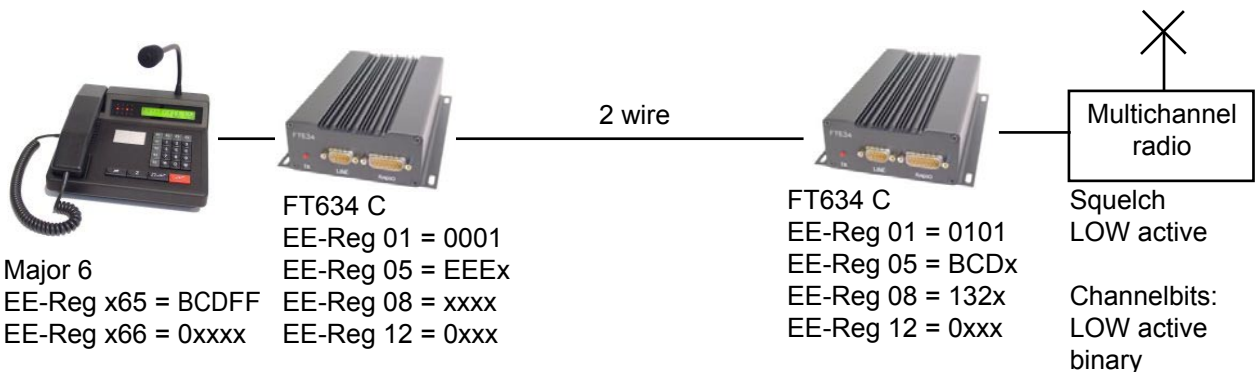

**Sample 7:** Controlhead Major 6, opposite a multichannel radio, with option line watching

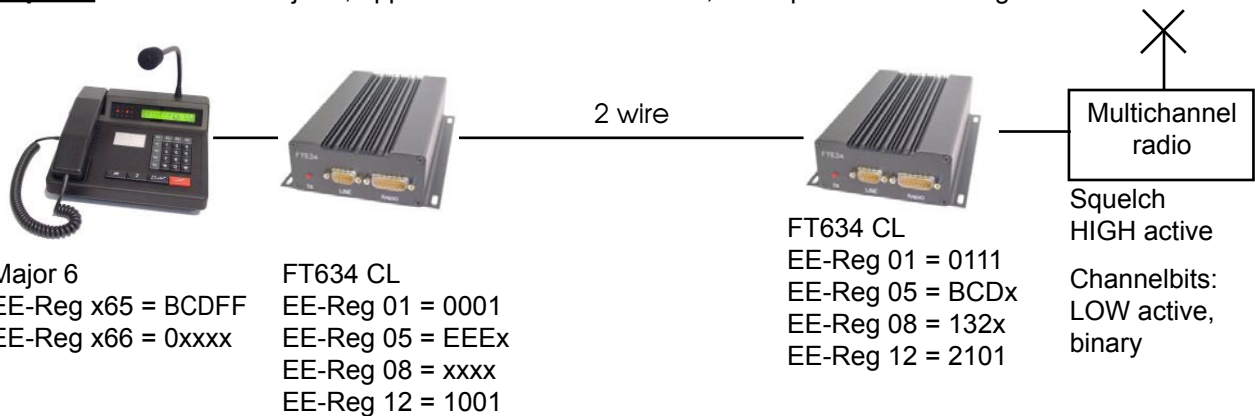

## Service Program, only with FT634C and FT634CL

The FT634C/CL have one RS232 interface (TTL, dont connect direct to PC) with following specification:

4800 bauds, 1 start bit, 8 data bits, no parity, 1 stop bit

The connections for the RS232 interface is either inside of the case on the 3-pin male connector ST4 or on the 64-pin DIN41612 connector ST1.

For programming you must use the interface RS232Ad1.

If the terminal is connected, you have access on the service program and some commands, like for example:

- programming the EEPROM
- transmitting of tone sequence
- service mode analog switch
- level tone transmitting

To start the service program, you simply enter at the terminal <Return> or <X>,<Return> .

### Programming mode EEPROM

To program a address <xx> with the content <yyyy>, do the following:

- 1) **Start** service program with <Return> or <X>,<Return>
- 2) **Read** register --> put in <Rxx>,<Return>  
=> At the screen appears: <>Register xx: wwwww
- 3) **Write** register --> put in <Pxxyyyy>,<Return>

xx = number of register  
yyyy = value of register

You find a list of all registers in the following section.

### Register encoding for

- 00 Impedance of the AC line
1. digit 0 = high input impedance  
1 = input impedance 600 ohms
  2. digit 0 = high output impedance  
1 = output impedance 600 ohms

## Register encoding for

- 01
1. digit, PTT/SQL switching
    - 0 = pilot tone evaluation (2 wire/simplex)  
{not with active SQL/PTT input!}
    - 1 = pilot tone evaluation (4 wire/duplex)  
{always!}
    - 2 = audio squelch (2 wire/simplex)  
{not with active SQL/PTT input!}
    - 3 = audio squelch (4 wire/duplex)  
{always!}
  2. digit, in silence switched through audio path
    - 0 = multi wire → AC line,  
switched by pilot tone evaluation
    - 1 = AC line → multi wire,  
switch by active squelch/PTT input
    - 2 = AC line → multi wire, without toggle
  3. digit, squelch/PTT input active if
    - 0 = LOW (<0,6V)
    - 1 = HIGH (> 3V)
  4. digit, if squelch/PTT input active then
    - 0 = pilot tone not transmitted to the AC line
    - 1 = pilot tone transmitted to the AC line
- 05
- 06
- 07
- 08
- 5 tone to switch the output, EEEE = disable  
last set digital outputs  
5 tone for digital inputs  
configurations for channel interface
1. digit, output logic
    - 0 = normally (1 = HIGH)
    - 1 = inverts (1 = LOW)
  2. digit, bit-interpretation
    - 2 = binary-1
    - 3 = binary
  3. digit, acknowledge mode (1. and 2. digit of telegram)
    - 0 = normally, without pilot tone
    - 1 = swaped, without pilot tone
    - 2 = swaped, with pilot tone
- 10
- Tone sequence for line watching
- 11
1. digit, master cycle time,  $n * 10$  sec
  2. digit, master cycle time,  $n * 1$  sec
  3. digit, slave cycle time,  $n * 10$  sec
  4. digit, slave cycle time,  $n * 1$  sec
- 12
1. digit, line watching
    - 0 = off
    - 1 = device is master
    - 2 = device is slave
  2. digit, line watching with pilot tone 1=on, 0=off
  3. digit, line failure indicated by
    - Bit 3 = ---
    - Bit 2 =---
    - Bit 1 = digital output 5
    - Bit 0 = digital output 4
  4. digit, line failure indicated by
    - Bit 3 = digital output 3
    - Bit 2 = digital output 2
    - Bit 1 = digital output 1
    - Bit 0 = digital output 0

## Adjustment

All FT634 delivered are on default levels. Please adjust the levels to your radio or controlhead. Also adjust the incoming level of the AC line. Follow the steps below.

### 1) Adjustment of AC line input:

- a) put in 1000 Hz at the pre-determined level into the ac line
- b) measuring on the testpoints MP1 and MP0 (GND) is normally -12 dBm
- c) turn R35 anticlockwise to the end
- d) adjust the level on R30
- e) put in 3400 Hz at the pre-determined level into the ac line
- f) adjust the frequency response on R35 to - 12 dBm, the max. gain for higher frequencies is 12 dB

### 2) Adjustment of the audio output to the radio or controlhead:

- a) put in 1000 Hz at the pre-determined level into the ac line
- b) put in jumper JP9 to position 2
- c) connect the radio or controlhead according to your application
- d) adjust R74 to get nomonally deviation
- e) put jumper JP9 back to position 1

### 3) Adjustment of the audio input coming from the radio or controlhead

- a) put in 1000 Hz at the pre-determined level to get maximum deviation
- b) measuring on the testpoints MP2 and MP0 (GND) is normally -12 dBm
- c) adjust the level on R79

## Configuration of the jumpers

1a) Configuration 4 wire mode: Set the jumpers JP1-JP8 accordingly

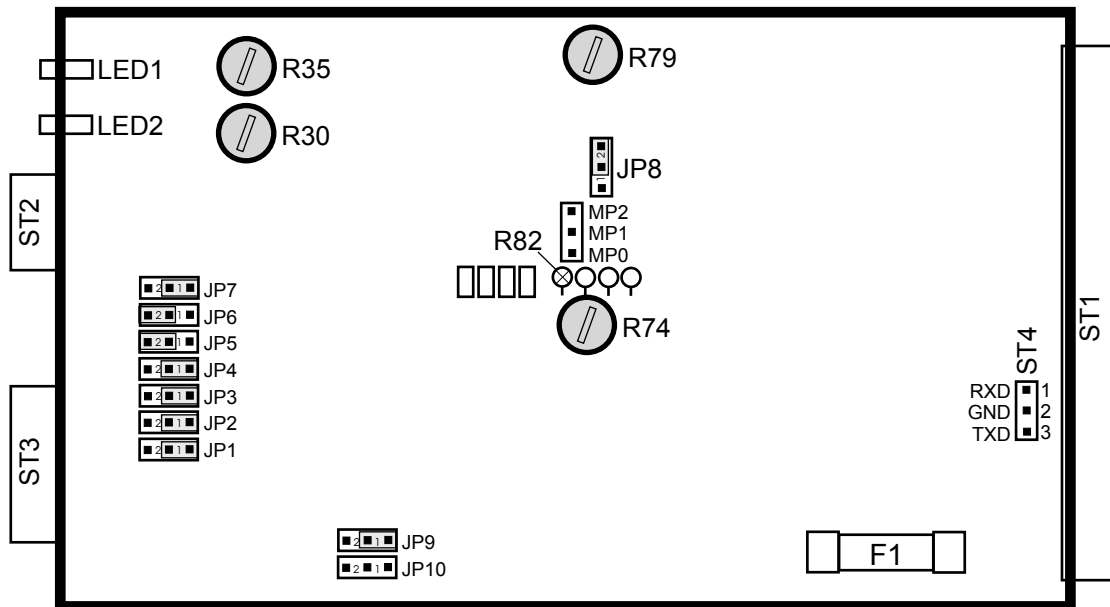

1b) Configuration 2 wire mode: Set the jumpers JP1-JP8 accordingly (**default on delivery**)

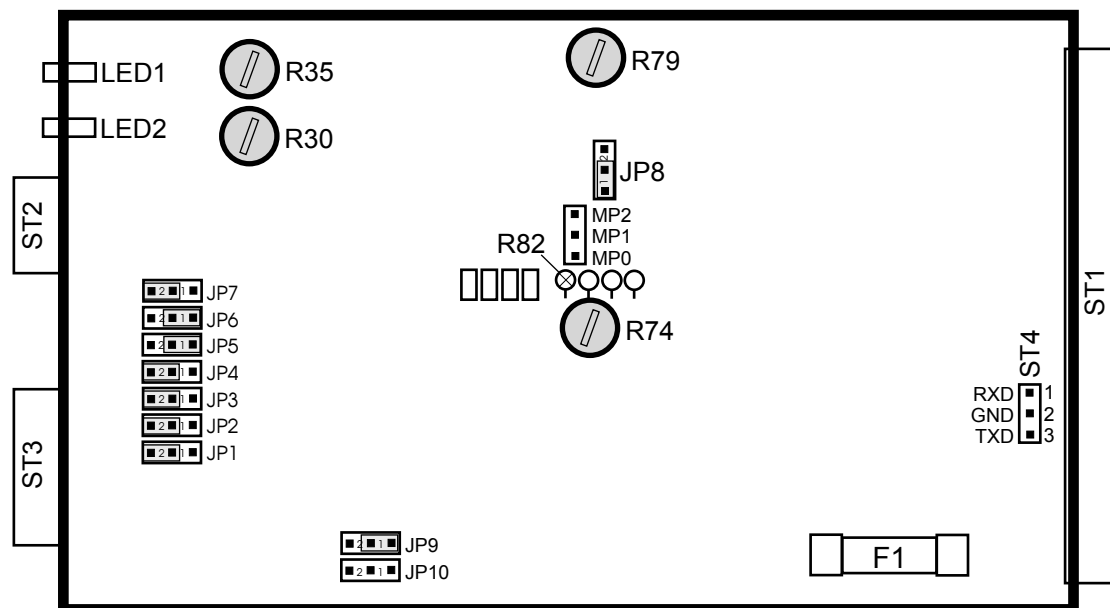

2) Configuration of squelch/ptt input (jumper **JP10**):



a) Set the jumper JP10 to position 2 for squelch/PTT active low.



b) Set the jumper JP10 to position 1 for squelch/PTT active high.

## Connectors FT 634, FT634C, FT634CL

### AC line

**Standard Box:** Connector **ST2** (9-pin D-Sub)  
**19" Box:** Connector **ST1** (64-pin DIN41612)

<b>Standard</b> pin/No.	<b>19"</b> pin/No.		
1	6c	Audio In/Out a	2 wire AC line
5	7c	Audio In/Out b	
1	6c	Audio Out a	4 wire AC line
6	5c	Audio Out b	
5	7c	Audio In a	
9	4c	Audio In b	

### Connector for radio

**Standard Box:** Connector **ST3** (15-pin D-Sub)  
**19" Box:** Connector **ST1** (64-pin DIN41612)

<b>Standard</b> pin/No.	<b>19"</b> pin/No.	
1+9	1a+c	+12 V supply
8+15	32a+c	GND
4	16c	Audio Out a (TX)
5	15c	Audio Out b (TX)
11	10c	Audio In a (RX)
12	11c	Audio In b (RX)
2	24c	PTT relais contact a
3	24a	PTT relais contact b

### Additional ports, only with version FT634C and FT634CL

10	26a	sqelch input
6	9a	digital out 0
7	10a	digital out 1
13	11a	digital out 2
14	12a	digital out 3
--	13a	digital out 4
--	14a	digital out 5
--	3a	digital in 0
--	4a	digital in 1
--	5a	digital in 2
--	6a	digital in 3
--	7a	digital in 4
--	8a	digital in 5

### Connector RS232

**Standard Box:** Connector **ST4** (3-pin)  
**19" Box:** Connector **ST1** (64-pin DIN41612)

<b>Standard</b> pin/No.	<b>19"</b> pin/No.		
1	20a	RXD	<b>Attention:</b> only TTL level, do <b>not</b> connect direct to PC, use interface RS232AD1, Order No. 901900
2	21a	GND	
3	22a	TXD	

# Technical Data

## Supply

Voltage	+ 12 V/DC - 8% + 40%
Supply current (FT 634)	60 mA
Supply current (FT 634 C/CL)	110 mA
Fuse	500 mA

## Input level AC line

Factory adjusted to	- 10 dBm (245 mV)
Adjusting range (R30)	- 30 dBm to - 6 dBm (25 to 390 mV)
Input impedance (normaly)	600 Ohm
Input impedance (high)	20/40 kOhm (2 wire/4 wire)

## Output level AC line

Output impedance	- 10 dBm (245 mV) 600 Ohm
------------------	------------------------------

## Input level radio/controlhead

Factory adjusted to	+ 3 dBm (1094 mV)
Adjusting range (R79)	- 24 dBm to + 6 dBm (49 to 1546 mV)
Input impedance	600 Ohm

## Output level radio/controlhead

Factory adjusted to	- 17 dBm (109 mV)
Adjusting range (R74)	- 30 dBm to + 5 dBm (25 to 1377 mV)
Output impedance	600 Ohm

## Pilot tone frequency

$f_c = 3300$  Hz

## Pilot tone notch filter

Absorption > 50 dB

## Weight

Standard version	550 g
19 Inch Box	530 g

## Dimensions

Standard version	130 x 46 x 180 mm
19 Inch Box	35 x 186 x 128 mm